

# Turret / Penthouse Louvres

## Description

For supply or extract air, designed to offer weather protection to roof-top openings. Neat welded mitred corners and all welded concealed frame ensure maximum rigidity whilst an attractive appearance is completed with its pitch roof construction.

## Construction

From extruded aluminium sections, frame 3.0mm - 5.0mm thick, with 1.6mm thick Blades. Aluminium roof 1.5mm thick, fully welded construction.

## Size and Weight

There are virtually no size constraints as large units are produced in multiple sections.

Average weight: 60.0kg/m<sup>2</sup>.

Average free area: 40%.

## Options

Extended turned down base angle

Access doors

Matt black rear blanking panels

Insulated blanking panels (Thermal & Acoustic)

Guards: Insect screen (Fixed or Removable)

## Product Specification

State Quantity, the product coding and the size

Length x Width x Height

e.g. 1 Qty. 5WTB1M+0C 1800 x 900 x 600 H.

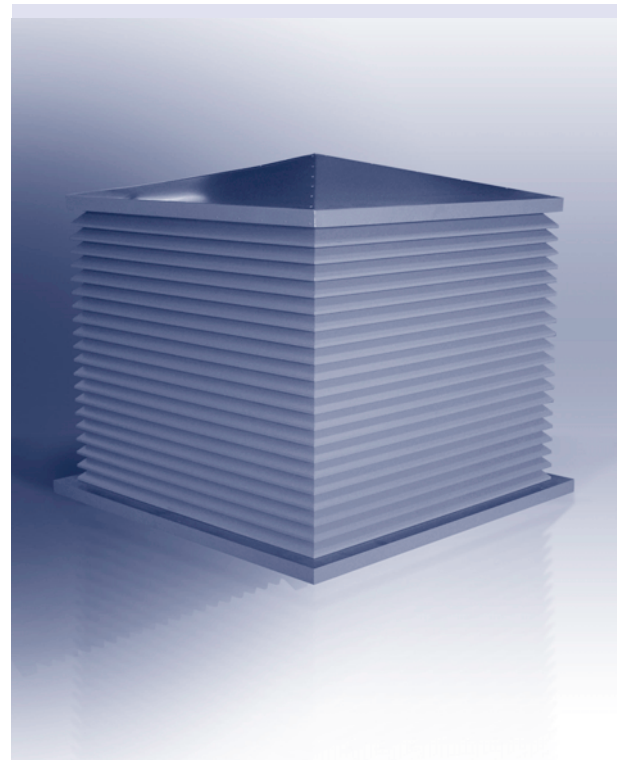

## Rain Defence

The 50mm & 75mm louvre systems have been tested by BSRIA to European standard EN13030:2002 and achieve Class C (80 - 94.9 % effectiveness).

## Airflow Performance

Tested to EN13030:2002 the following aerodynamic coefficient is achieved :

50mm Intake ~ 0.253.

75mm Intake ~ 0.258.

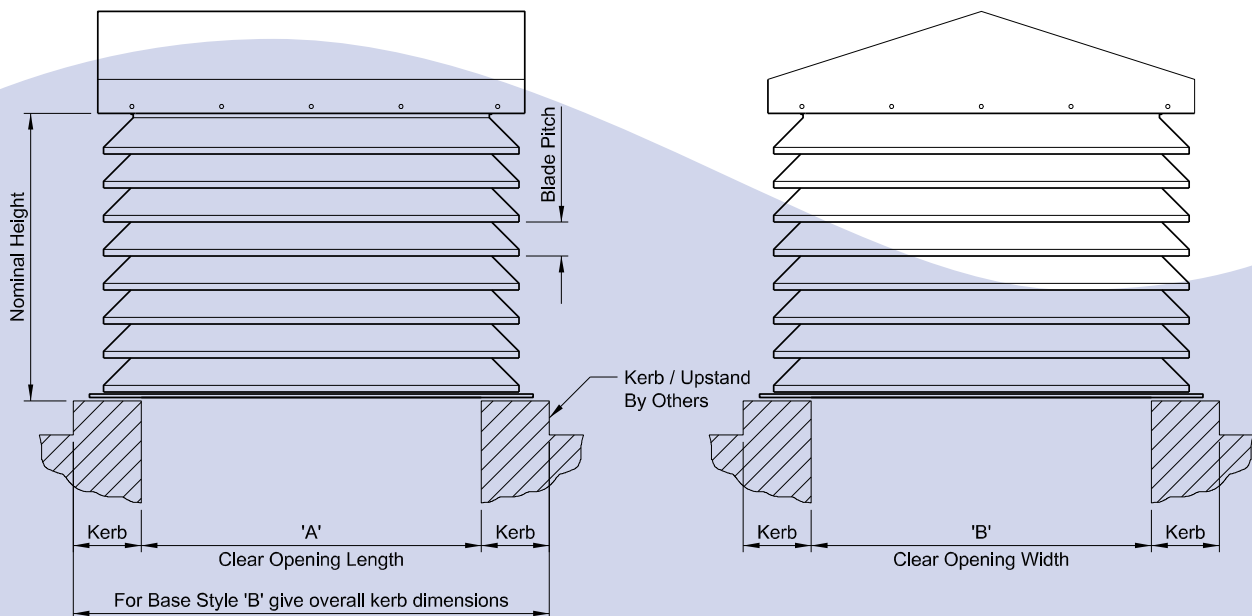

Blade Pitch	Product Type	Base Style	Options	Mesh Options
<b>5</b> 50 mm Blade Pitch	<b>WT</b> Turret Louvre	<b>A</b> Standard Base	<b>1</b> None	<b>M</b> Bird Mesh
<b>7</b> 75 mm Blade Pitch		<b>B</b> Extended Turned Down Base Angle		<b>I</b> Insect Mesh
				<b>0</b> None



Fixings	Finish
<b>0</b> None	<b>D</b> Mill Finish
<b>1</b> Extended Corner Posts	<b>C</b> PPC BS / RAL Colour

# Turret / Penthouse Louvres

## Base Style Options

Type	Dim 'p' (mm)	Dim 'd' (mm)
5WTA	50	76
7WTA	75	102

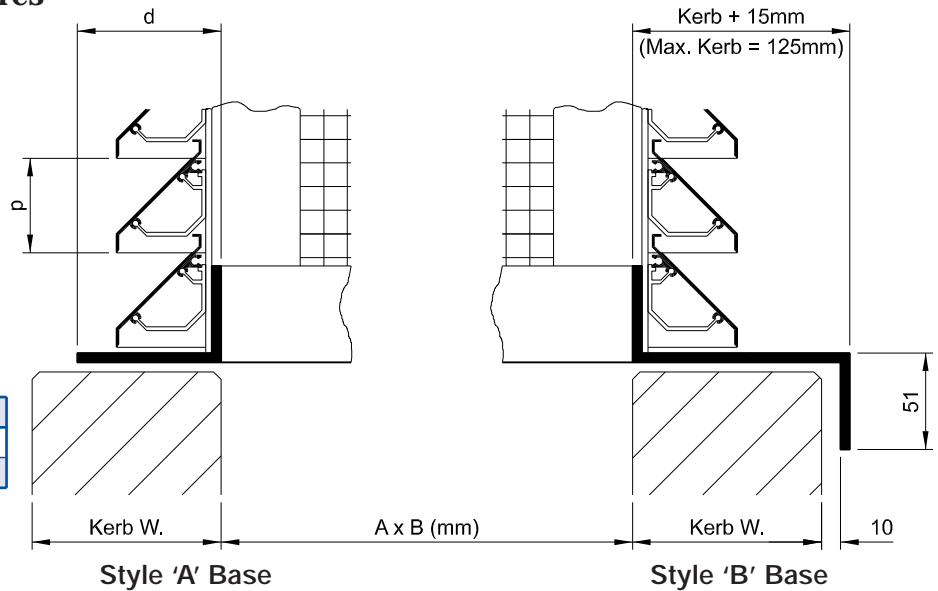

LOUVRES

## Multiple Section Units

Larger sized penthouse louvres are supplied in multiple sections for site assembly.  
 All connecting mullions and penthouse roof fixing points are pre-drilled for ease of assembly.  
 Full bolt kit is provided for louvre assembly.

Where transport or access restrictions are a consideration, any sized penthouse unit can be supplied in kit-form sections upon request.

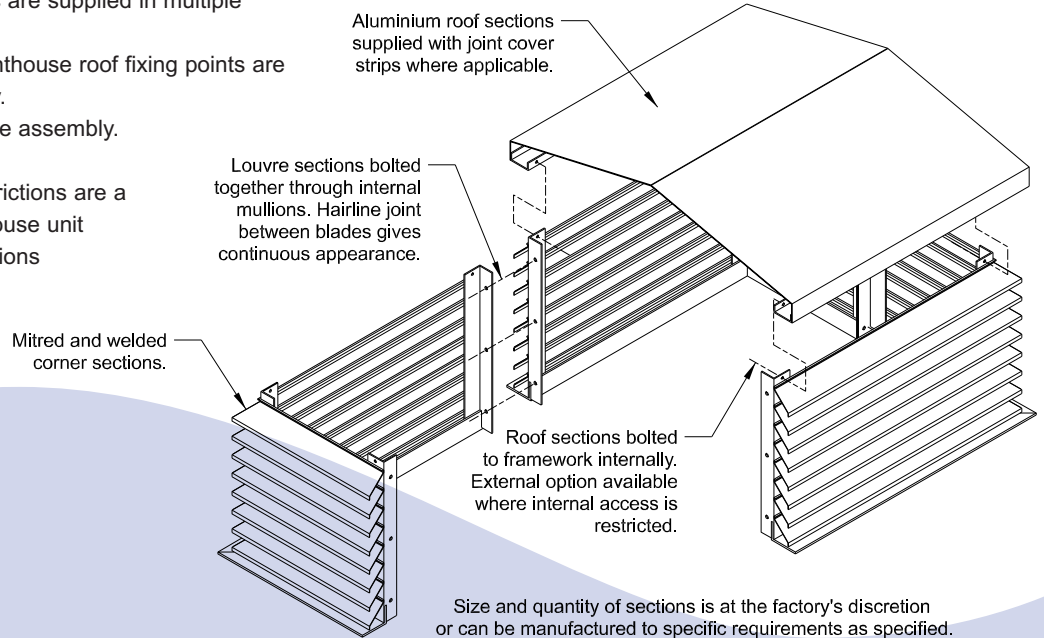

## Recommended Fixing Options

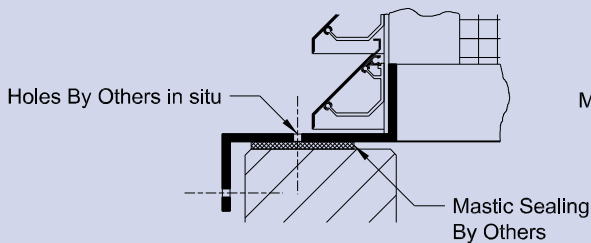

### Code '+0' fixings (Standard)

Fixings through base angle into kerb / upstand

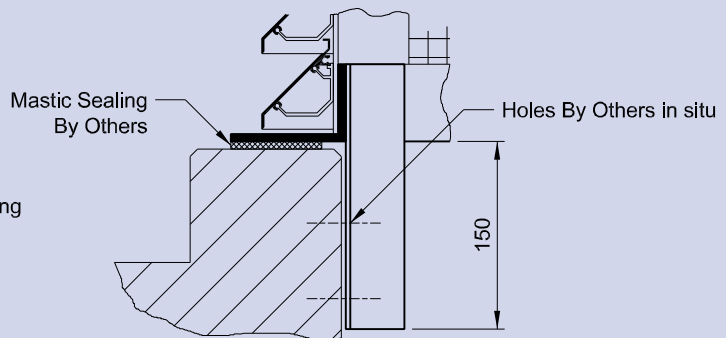

### Code '+1' fixings

Internal extended corner posts.  
 Larger units also have intermediate extended posts for additional fixings.

# Technical Data Turret / Penthouse Louvres

- i) Data is based upon louvres fitted with a rear bird guard / debris screen. With an insect screen fitted the free area will be reduced by approximately 15%.
- ii) Low, wide turret louvres perform more efficiently and offer better weather protection than tall narrow units.
- iii) To minimise the risk of rain ingress, intake louvres should be selected against a max face velocity of 1.5M/s.
- iv) Pressure drops are total, given in Pascals, and based on air density of 1.2Kg/M<sup>3</sup>.
- v) NC ratings shown are given for general guidance only.

## Selection Procedure

- a) 
$$\frac{\text{Air Volume (M}^3\text{/s)}}{\text{Face Velocity (M/s)}} \quad \text{Multiply x 1.2 = Nominal Louvre Area (M}^2\text{)}$$
- b) Determine the air volume flow rate required to pass through the louvre (M<sup>3</sup>/s).
- c) Determine the maximum acceptable pressure drop (pa).
- d) From the adjacent chart look up face velocity (M/s) against maximum pressure drop.
- e) Divide air volume by face velocity & multiply x 1.2 to give required nominal louvre area.

## Selection Example

- a) Size a 5WT1M Turret louvre to intake 6.0M<sup>3</sup>/s at the recommended face velocity of 1.5M/s.
- b) Determine the pressure drop from the adjacent chart. At 1.5M/s a pressure drop of 21pa is given.
- b) Apply the formula as follows:

$$\frac{6.0 \text{ Air Volume (M}^3\text{/s)}}{1.5 \text{ Face Velocity (M/s)}} \quad 4 \times 1.2 = 4.8\text{M}^2 \text{ Nominal Louvre Area}$$

- c) Select a square or rectangular base size and calculate an appropriate height to give the above nominal louvre area; e.g. 1500 x 1500 x 800 H.

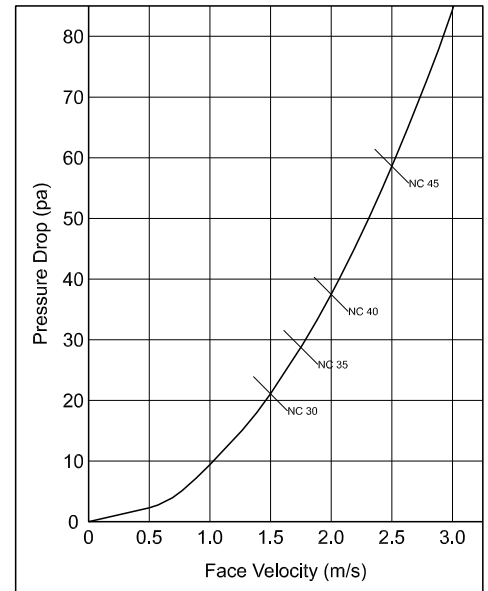

A range of sizes is given in the table below for general guidance. In between sizes and larger sized units than shown are also available.

'Nominal Louvre Area' Values in M <sup>2</sup> For Turret Louvres 5WT & 7WT															
Nom. Opening Size A x B (mm)	Height Dimensions (mm)														
	300	400	450	500	600	700	750	800	900	1000	1100	1200	1300	1400	1500
300 x 300	0.36	0.48													
400 x 400	0.48	0.64													
500 x 500	0.6	0.8	0.9	1.0	1.2										
600 x 300	0.54	0.72	0.81	0.9	1.08										
600 x 450	0.63	0.84	0.95	1.05	1.26										
600 x 600	0.72	0.96	1.08	1.2	1.44										
700 x 400	0.66	0.88	0.99	1.1	1.32										
700 x 500	0.72	0.96	1.08	1.2	1.44										
700 x 700	0.84	1.12	1.26	1.4	1.68	1.96									
750 x 750		1.2	1.35	1.5	1.8	2.1	2.25								
800 x 400		0.96	1.08	1.2	1.44	-	-								
800 x 600		1.12	1.26	1.4	1.68	1.96	-								
800 x 800		1.28	1.44	1.6	1.92	2.24	2.4	2.56							
900 x 450			1.22	1.35	1.62	-	-	-							
900 x 600			1.35	1.5	1.8	2.1	2.25	-							
900 x 900			1.62	1.8	2.16	2.52	2.7	2.88	3.24						
1000 x 500			1.35	1.5	1.8	2.1	2.25	-	-						
1000 x 750				1.75	2.1	2.45	2.63	2.8	3.15	3.5					
1000 x 1000				2.0	2.4	2.8	3.0	3.2	3.6	4.0					
1100 x 1100				2.2	2.64	3.08	3.3	3.52	3.96	4.4	4.84				
1200 x 600				1.8	2.16	2.52	2.7	2.88	3.24	-	-				
1200 x 900				2.1	2.52	2.94	3.15	3.36	3.78	-	-				
1200 x 1200				2.4	2.88	3.36	3.6	3.84	4.32	4.8	5.28	5.76			
1500 x 750				2.25	2.7	3.15	3.38	3.6	4.05	4.5	-	-			
1500 x 1000				2.5	3.0	3.5	3.75	4.0	4.5	5.0	5.5	6.0			
1500 x 1250				2.75	3.3	3.85	4.13	4.4	4.95	5.5	6.05	6.6			
1500 x 1500				3.0	3.6	4.2	4.5	4.8	5.4	6.0	6.6	7.2	7.8	8.4	9.0
1800 x 900				2.7	3.24	3.78	4.05	4.32	4.86	5.4	5.94	6.48	-	-	-
1800 x 1200				3.0	3.6	4.2	4.5	4.8	5.4	6.0	6.6	7.2	-	-	-
1800 x 1800					4.32	5.04	5.4	5.76	6.48	7.2	7.92	8.64	9.36	10.08	10.8
2000 x 1000					3.6	4.2	4.5	4.8	5.4	6.0	6.6	7.2	7.8	8.4	9.0
2000 x 1500							5.25	5.6	6.3	7.0	7.7	8.4	9.1	9.8	10.5
2000 x 2000							6.0	6.4	7.2	8.0	8.8	9.6	10.4	11.2	12.0

Unless specified otherwise, unit sizes shown in the shaded areas above and larger sizes will be manufactured in multiple sections for site assembly.