

## 75mm Single Bank Weather Louvres

### Description

For intake or extract air, the 45° blades are fixed at 75mm centres and have excellent integral rain defence features. Heavy duty construction allows large panels to be produced with unbroken blades.

Larger areas can be covered using multiple panel assemblies which will incorporate concealed rear mullions to give continuous blade appearance throughout.

### Construction

From extruded aluminium sections, frame 3.0mm thick, blades 2.0mm thick. All frames to be of fully welded construction. Fitted as standard with rear galvanised steel bird mesh screen.

### Size and Weight

From 600 x 600 to 3500 x 3500 in a single unit. Larger sizes are available in multiple units. Concealed rear mullions when width exceeds 1200mm.

Average weight: 12.75kg/m<sup>2</sup>.

Average free area: 48%.

### Rain Defence

The 75mm louvre system has been tested by BSRIA to European standard EN13030:2002 and achieves Class C - (80 - 94.9 % effectiveness).

### Airflow Performance

Tested to EN13030:2002 the following aerodynamic coefficient is achieved : Intake ~ 0.258

### Options

Matt black rear blanking panels

Insulated blanking panels (Thermal & Acoustic)

Mitred corners

Guards: Insect screen (Fixed or Removable), Security

Special shapes, Circular, triangular etc.

### Product Specification

State Quantity, the product coding and the size

Width x Height

e.g. 1 Qty. W7050+0C 3000 x 2000



Frame Style	Panel Options	Mesh Options	Accessories
<b>W7</b> 50mm Flange	<b>0</b> Single Panel	<b>5</b> Bird Mesh	<b>0</b> None
<b>W6</b> Recessed Frame	<b>1</b> Multi-Panel Narrow Line Face Mullion	<b>7</b> Insect Mesh	<b>9</b> Drain Cill
<b>W9</b> Frameless Panel	<b>2</b> Multi-Panel Concealed Rear Mullion	<b>0</b> None	



Fixings	Finish
<b>0</b> None	<b>D</b> Mill Finish
<b>1</b> Flange Holes	<b>C</b> PPC BS / RAL Colour
<b>2</b> Rear Fixing Lugs C/W Tee Bolts	<b>J</b> Anolok Anodised

# 75mm Single Bank Weather Louvres

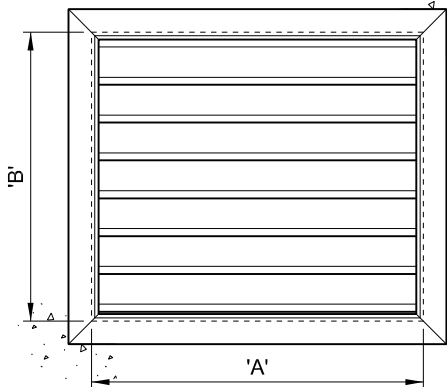

Size is expressed as 'A' x 'B' and relates to the nominal opening size into which the louvre is to be offered. A manufacturing size reduction tolerance is provided. Dimension 'A' (Width) should be stated first followed by dimension 'B' (Height).

Louvre blades are supported at a maximum of 1200mm centres. Multi-Panel louvres and panels exceeding 1200mm, incorporate heavy duty rear mullions and blade support clips to give continuous line appearance from the face. These are accommodated within the frame shown above and do not increase the depth dimension of the louvre.

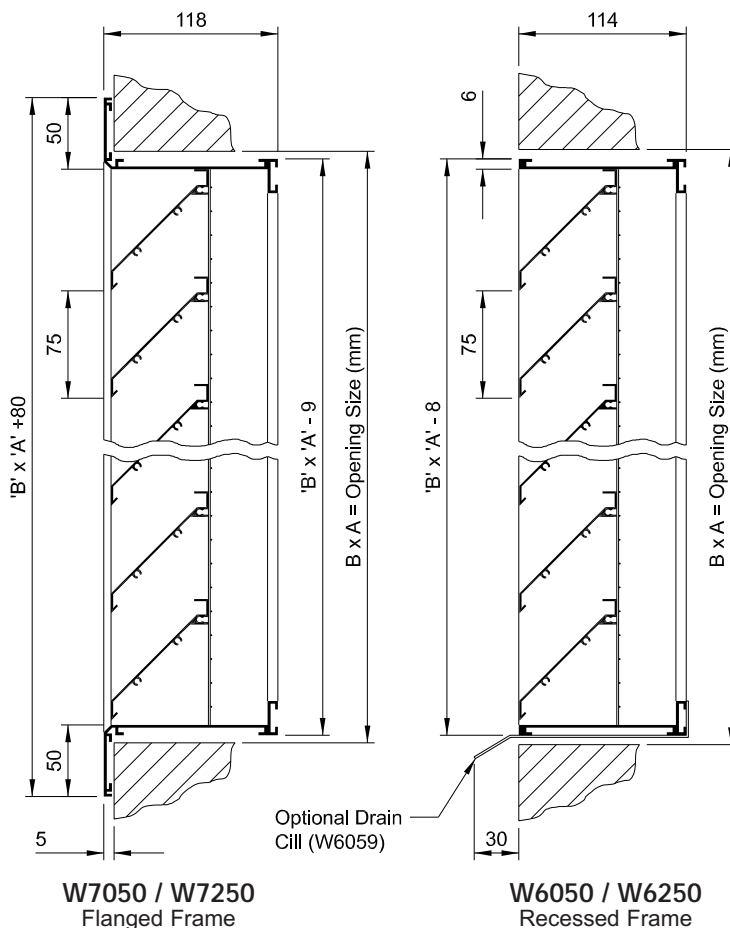

LOUVRES

## Technical Data

- i) Data is based upon louvres fitted with a rear bird guard / debris screen.  
With an insect screen fitted the free area will be reduced by approximately 15%.
- ii) To minimise the risk of rain ingress, intake louvres should be selected against a max face velocity of 1.5M/s.
- iii) Pressure drops are total, given in Pascals, and based on air density of 1.2Kg/M<sup>3</sup>.
- iv) NC ratings shown are given for general guidance only.

## Selection Procedure

- a)  $\frac{\text{Air Volume (M}^3\text{/s)}}{\text{Face Velocity (M/s)}} = \text{Louvre Face Area (M}^2\text{)}$
- b) Determine the air volume flow rate required to pass through the louvre (M<sup>3</sup>/s).
- c) Determine the maximum acceptable pressure drop (pa).
- d) From the adjacent chart look up face velocity (M/s) against maximum pressure drop.
- e) Divide air volume by face velocity to give required louvre face area.

## Selection Example

- a) Size a W7 (75mm blade pitch) louvre to exhaust 5.0M<sup>3</sup>/s at 70 Pascals total pressure.
- b) At 70 Pa, a 'Face Velocity' of 2.75M/s is given in the adjacent pressure drop graph; thus apply the formula as follows:  
 $\frac{5.0 \text{ Air Volume (M}^3\text{/s)}}{2.75 \text{ Face Velocity (M/s)}} = 1.8\text{M}^2 \text{ Louvre Face Area}$
- c) Select a square or rectangular size to give the above face area, e.g. 1800w. x 1000h.

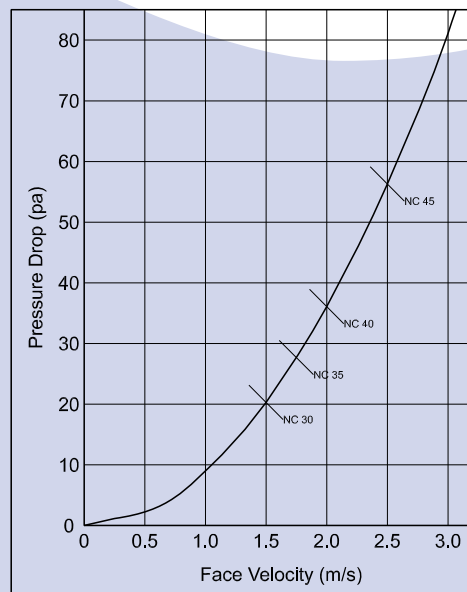

# 50mm & 75mm Weather Louvres Multi-Panel Options

## 1 Multi-Panel Narrow Line Face Mullion

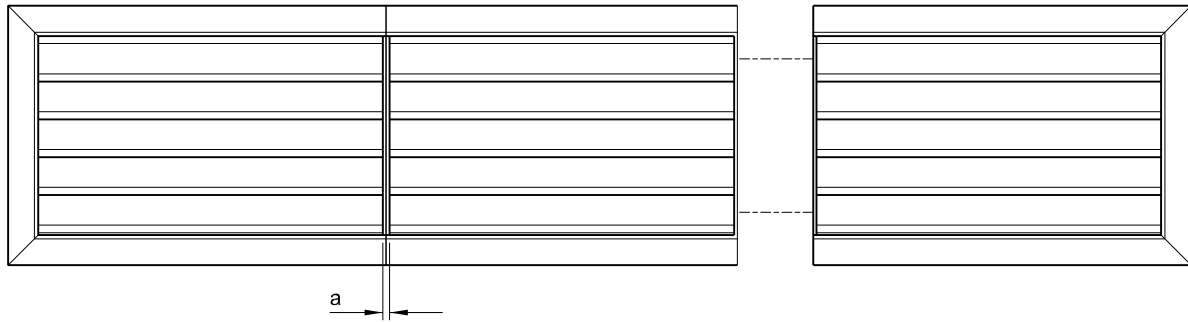

Type	Dim 'a' (mm)
W51	10
W41	10
W11	10
W71	14
W61	14

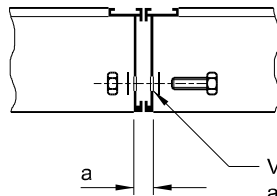

Vertical narrow line mullion at each joint pre-drilled with bolt holes for site assembly

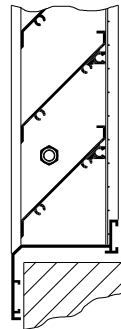

## 2 Multi-Panel Concealed Rear Mullion

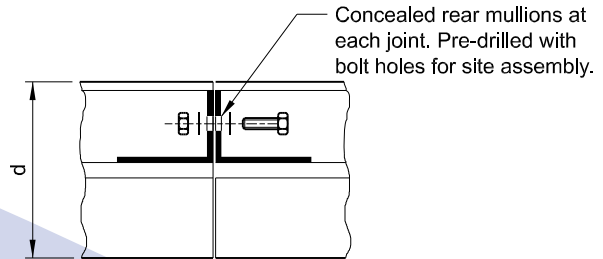
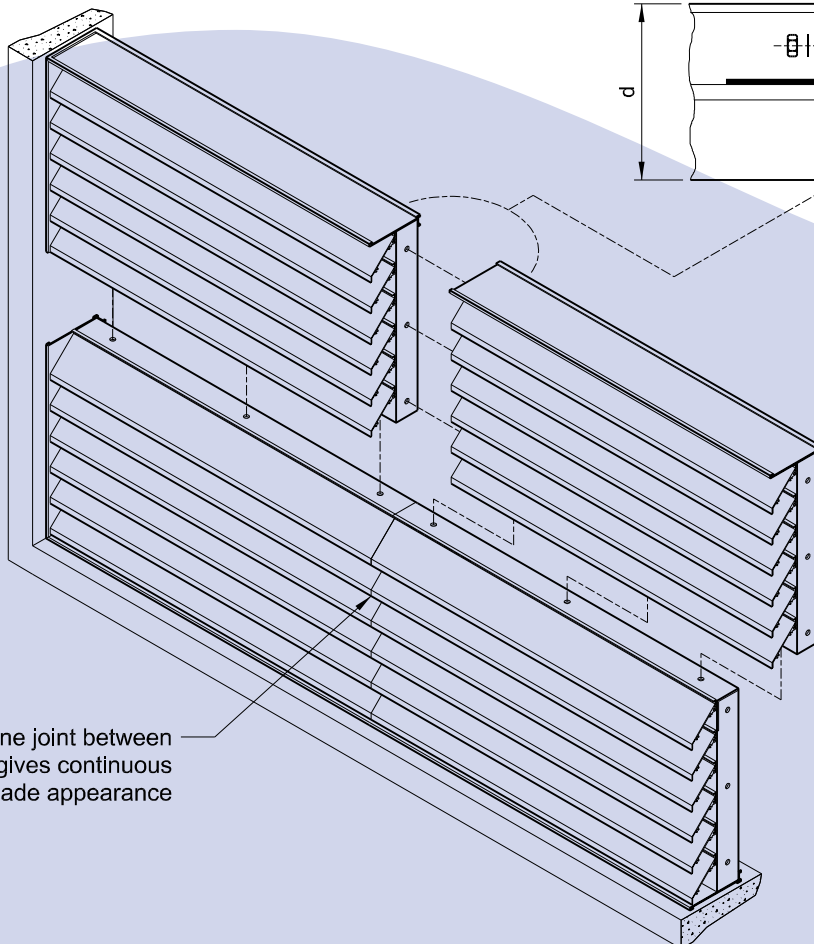

Concealed rear mullions at each joint. Pre-drilled with bolt holes for site assembly.

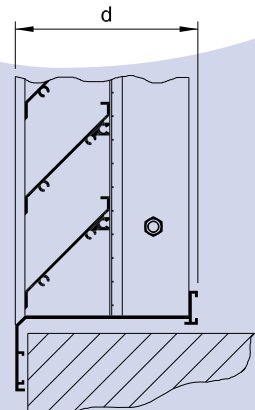

Type	Dim 'd' (mm)
W52	118
W42	114
W12	90
W72	118
W62	114

# Weather Louvre Fixing Options

**+ 0** None

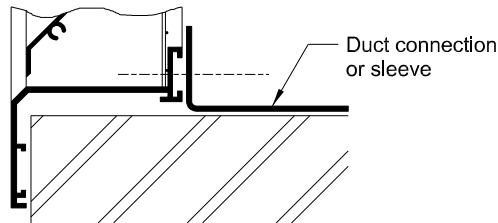
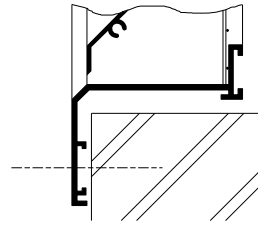
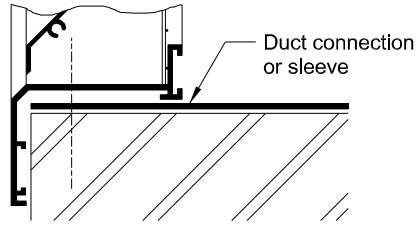

Fixings by installers via positions indicated in situ. From the face of the louvre it is possible to fix between the louvre blades via the side frames. Use code +0 as the 6th digit of the product coding. Final sealing by installers.

**+ 1** Flange Holes

Pre-punched or drilled flange holes to take No.8 self-tapping screws. Hole position at the discretion of the factory, unless stated otherwise.

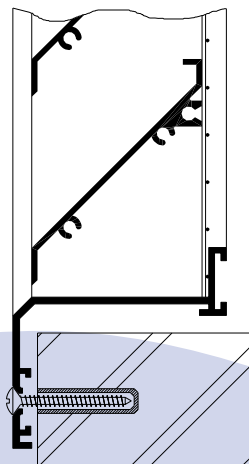

**+ G** Glazing Bar

25mm or 28mm glazing bar welded around the perimeter of louvre frame. Suitable for double glazing frame applications. Available on louvre types 'W4' and 'W6'. Specify the overall glass size which the louvre is to replace and glass thickness (25mm or 28mm)

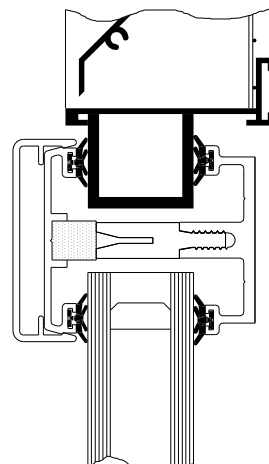

**+ 2** Rear Fixing Lugs C/W Tee Bolts

Fixing style '+2' is intended for the larger sized louvre panel with either flanged framing or recess style frame. Specially formed 'Tee bolts' traverse within the track at the rear of frame. Bolts and brackets supplied but quantity at the factory's discretion.

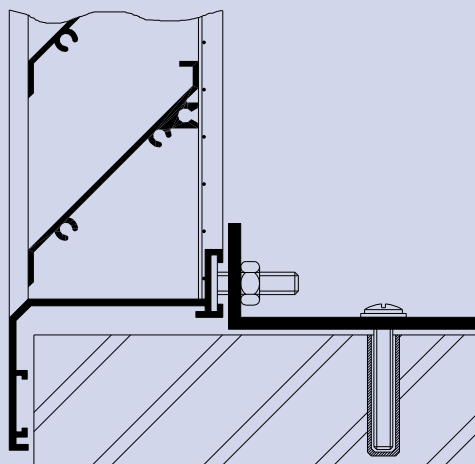

**+ 4** Rear Fixing Lugs

Fixing style '+4' is ideal for small to medium sized louvre panels. Brackets are of 1.6mm galvanised sheet steel folded but undrilled. Screws and bolts supplied by others. Brackets should be affixed direct to rear of louvre frame by self-tapping screws. The quantity of brackets is at the factory's discretion (minimum 4 No.)

