

50mm Double Bank Weather Louvres

Description

For intake or extract air, the 45° blades are fixed at 50mm centres and arranged in double bank formation to offer higher levels of rain defence effectiveness.

Heavy duty construction allows large panels to be produced with unbroken blades. Larger areas can be covered using multiple panel assemblies which will incorporate narrowline visible mullions.

Construction

From extruded aluminium sections, frame 3.0mm thick, blades 2.0mm thick. All frames to be of fully welded construction. Fitted as standard with rear galvanised steel bird mesh screen.

Size and Weight

From 600 x 600 to 3000 x 2000 in a single unit. Larger sizes are available in multiple units. Concealed rear mullions when width exceeds 1200mm.

Average weight: 25.0 kg/m².

Average free area: 48%.

Product Specification

State Quantity, the product coding and the size Width x Height

e.g. 1 Qty. 5WA4M+0C 2500 x 1800

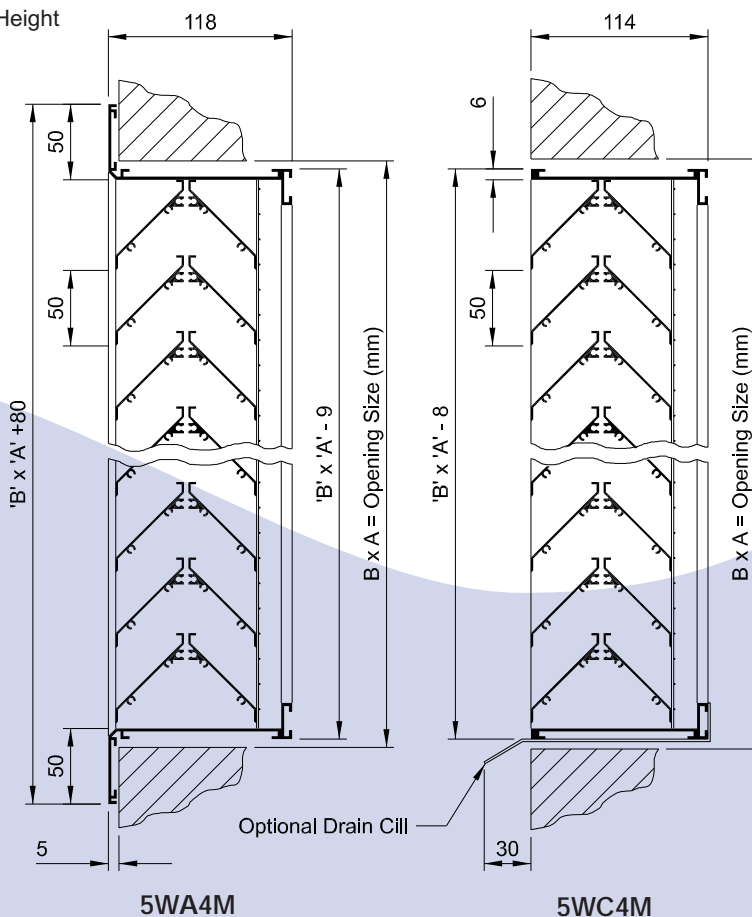
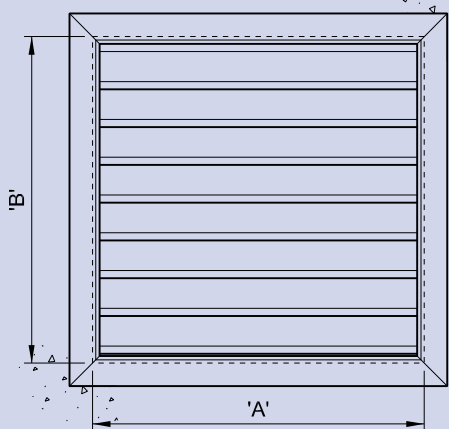

Blade Pitch	Frame Style	Options	Mesh Options
5 50mm Blade Pitch	WA Flanged Frame	4 Double Bank Chevron	M Bird Mesh
	WC Recessed Frame		I Insect Mesh
			0 None



Fixings	Finish
0 None	D Mill Finish
1 Flange Holes	C PPC BS / RAL Colour
2 Rear Fixing Lugs C/W Tee Bolts	

Weather Louvre Fixing Options

+ 0 None

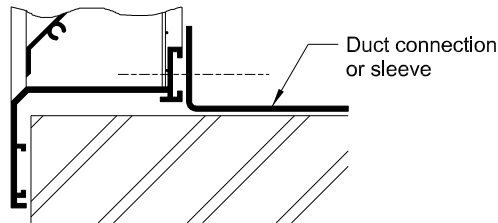
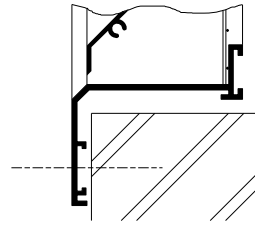
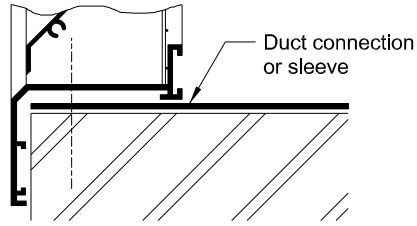

Fixings by installers via positions indicated in situ. From the face of the louvre it is possible to fix between the louvre blades via the side frames. Use code +0 as the 6th digit of the product coding. Final sealing by installers.

+ 1 Flange Holes

Pre-punched or drilled flange holes to take No.8 self-tapping screws. Hole position at the discretion of the factory, unless stated otherwise.

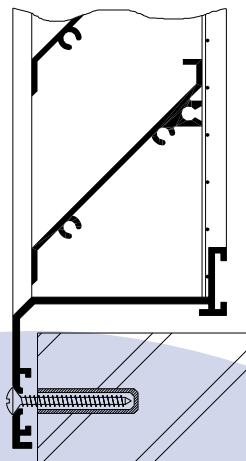

+ G Glazing Bar

25mm or 28mm glazing bar welded around the perimeter of louvre frame. Suitable for double glazing frame applications. Available on louvre types 'W4' and 'W6'. Specify the overall glass size which the louvre is to replace and glass thickness (25mm or 28mm)

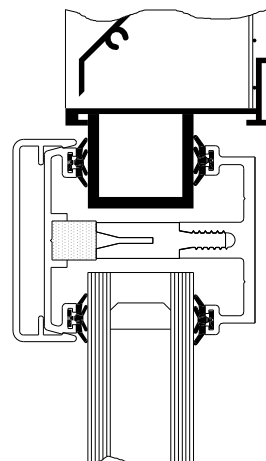

+ 2 Rear Fixing Lugs C/W Tee Bolts

Fixing style '+2' is intended for the larger sized louvre panel with either flanged framing or recess style frame. Specially formed 'Tee bolts' traverse within the track at the rear of frame. Bolts and brackets supplied but quantity at the factory's discretion.

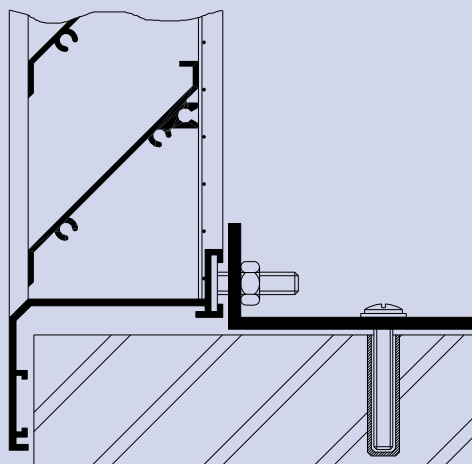

+ 4 Rear Fixing Lugs

Fixing style '+4' is ideal for small to medium sized louvre panels. Brackets are of 1.6mm galvanised sheet steel folded but undrilled. Screws and bolts supplied by others. Brackets should be affixed direct to rear of louvre frame by self-tapping screws. The quantity of brackets is at the factory's discretion (minimum 4 No.)

